

# WMC / WMC-F

## CARATTERISTICHE - SPECIFICATIONS

|                    |                     | WMC                     | WMC-F          |
|--------------------|---------------------|-------------------------|----------------|
| IN                 | <b>DIAMETER</b>     | 1/2 BSP                 | 1/2 BSP        |
|                    | <b>PRESS.</b>       | Min. -0.1 bar - 1.5 PSI | 1 bar - 15 PSI |
|                    |                     | Max. 6 bar 87 PSI       | 6 bar 87 PSI   |
| <b>TEMP.</b>       | Max. 60° C. 140° F. |                         |                |
| <b>OUT</b>         | <b>DIAMETER</b>     | 3/8 BSP                 |                |
| <b>SHAFT</b>       |                     | HOLLOW 28 mm            |                |
| <b>OIL</b>         | SAE 75W 90          | 0.6 litri               | 0.16 U.S.G.    |
| <b>PESO WEIGHT</b> | Kg / lbs            | 7.6 / 16.7              |                |



**M** = IEC 100-112 B14-28mm



|          |  |    |    |    |   |
|----------|--|----|----|----|---|
| WMC      |  | Dx | T  | R  | B |
| WMC-F    |  | Dx | B  | Bz | R |
| OPTIONAL |  | Sx | Bz |    |   |

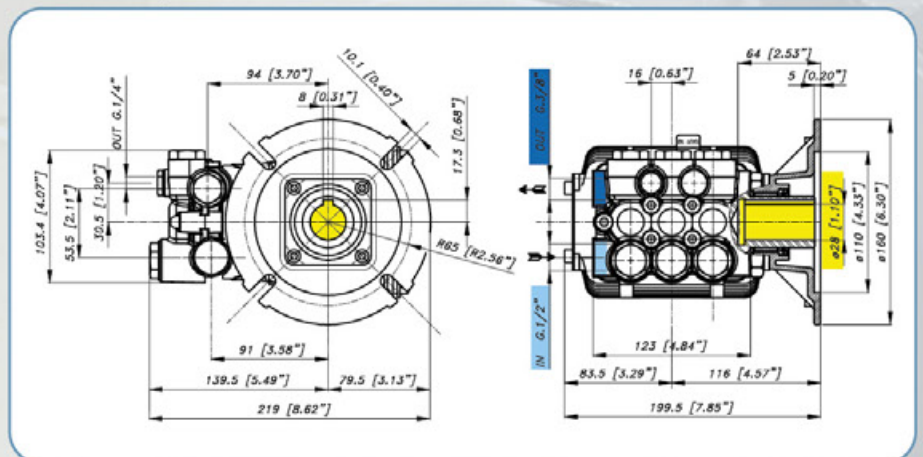

## CARATTERISTICHE - FEATURES

WMC 1450 rpm

## PERFORMANCE CHART

| CODICE<br>PART NR. | MODELLO<br>MODEL | PRESS MAX / MAX PRESSURE |      | PORTATA / FLOW |     | POTENZA / POWER |     | PIST.<br>PLUNG.<br>Dia. mm | CORSA<br>STROKE<br>mm |
|--------------------|------------------|--------------------------|------|----------------|-----|-----------------|-----|----------------------------|-----------------------|
|                    |                  | Bar                      | PSI  | L/min          | GPM | KW              | HP  |                            |                       |
| 04.8050.97.3       | WMC 1117         | 170                      | 2500 | 11             | 2.9 | 3.3             | 4.5 | 18                         | 9.8                   |
| 04.8051.97.3       | WMC 1217         | 170                      | 2500 | 12             | 3.1 | 3.6             | 5   | 18                         | 10.8                  |
| 04.8052.97.3       | WMC 1316         | 170                      | 2500 | 13             | 3.4 | 4               | 5.5 | 18                         | 12.4                  |
| 04.8053.97.3       | WMC 1515         | 150                      | 2200 | 15             | 3.9 | 4               | 5.5 | 18                         | 13.6                  |

WMC-F 2800 rpm

|              |            |     |      |    |     |     |     |    |      |
|--------------|------------|-----|------|----|-----|-----|-----|----|------|
| 04.8060.97.3 | WMC 1114 F | 140 | 2000 | 11 | 2.9 | 2.9 | 4   | 15 | 8    |
| 04.8061.97.3 | WMC 1120 F | 200 | 2900 | 11 | 2.9 | 4   | 5.5 |    |      |
| 04.8062.97.3 | WMC 1316 F | 160 | 2350 | 13 | 3.4 | 4   | 5.5 | 15 | 9.8  |
| 04.8063.97.3 | WMC 1320 F | 200 | 2900 | 13 | 3.4 | 5.1 | 7   |    |      |
| 04.8064.97.3 | WMC 1515 F | 150 | 2200 | 15 | 3.9 | 4   | 5.5 | 15 | 10.8 |
| 04.8065.97.3 | WMC 1520 F | 200 | 2900 | 15 | 3.9 | 5.5 | 7.5 |    |      |