

highest quality state of the art
 CUSTOMER QUALITY
 DRUGS
 customized
 PUMP

WMH WMH-F

CARATTERISTICHE - SPECIFICATIONS

		WMH	WMH-F
IN	DIAMETER	1/2 BSP	1/2 BSP
	PRESS.	Min. -0.1 bar -1.5 PSI	1 bar 15 PSI
		Max. 6 bar 87 PSI	6 bar 87 PSI
TEMP.	Max. 60° C. 140° F.		
OUT	DIAMETER	3/8 BSP	
SHAFT		HOLLOW 5/8"	
OIL	SAE 75W 90	0.6 litri	0.16 U.S.G.
PESO WEIGHT	Kg lbs	7.6 / 16.7	



M - NEMA 56C -5/8"



WMH							
WMH-F							
OPTIONAL							

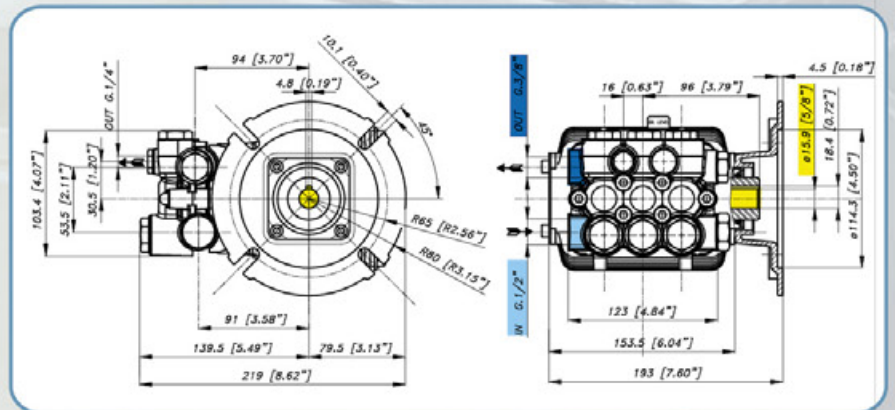

CARATTERISTICHE - FEATURES PERFORMANCE CHART

CODICE PART NR.	MODELLO MODEL	PRESS MAX / MAX PRESSURE		PORTATA / FLOW		POTENZA / POWER		PIST. PLUNG. Dia. mm	CORSA STROKE mm
		Bar	PSI	L/min	GPM	KW	HP		
04.8300.97.3	WMH 1525	103	1500	9.5	2.5	1.8	2.5	18	7.2
04.8301.97.3	WMH 1825	125	1800	9.5	2.5	2.3	3		
04.8302.97.3	WMH 2525	170	2500	9.5	2.5	2.9	4		
04.8303.97.3	WMH 2228	150	2200	10.6	2.8	2.9	4	18	8.6
04.8304.97.3	WMH 1833	125	1800	12.5	3.3	2.9	4	18	9.8
WMH-F 3450 rpm									
04.8513.97.3	WMH 1528 F	105	1500	10.2	2.7	2.1	2.8	15	6
04.8512.97.3	WMH 2528 F	175	2500	10.0	2.6	3.4	4.5		
04.8500.97.3	WMH 1932 F	130	1900	12.0	3.2	3.1	4.1	15	7.2
04.8501.97.3	WMH 2532 F	175	2500	12.0	3.2	4.1	5.4		
04.8502.97.3	WMH 1638 F	110	1600	14.3	3.8	3.1	4.2	15	8.6
04.8503.97.3	WMH 2038 F	140	2000	14.3	3.8	3.9	5.2		
04.8504.97.3	WMH 1543 F	105	1500	16.3	4.3	3.3	4.4	15	9.8
04.8505.97.3	WMH 1843 F	125	1800	16.3	4.3	4.0	5.3		