

highest state PRECISION QUALITY OF THE ART highest customized QUALITY PRECISION

KKL

CARATTERISTICHE - SPECIFICATIONS

IN	DIAMETER	\varnothing	1" BSP
	PRESS.	Min.	-0.1 bar - 1.5 PSI
		Max.	6 bar 87 PSI
TEMP.	Max.	74° C. 166° F.	
OUT	DIAMETER	\varnothing	1/2 BSP
SHAFT		\varnothing	24 mm
OIL		SAE 75W90	1.4 litri 0.37 U.S.G.
PESO WEIGHT		Kg lbs	16.1 / 35.4



FLANGIA CON GIUNTO ELASTICO PER MOTORI IDRAULICI (vedi pag. 76)
BELL HOUSING + FLEXIBLE COUPLING FOR HYDRAULIC MOTORS (see page 76)

BRIDE AVEC ACCOUPLEMENT ELASTIQUE POUR MOTEURS HYDRAULIQUES (voir page 76)
BRIDA CON JUNTA ELÁSTICA PARA MOTORES HIDRÁULICOS (véase pag. 76)



INTELLIseal™



Dx R B T

OPTIONAL

F Sx G M

INTELLIseal H.W.™

KIT PIEDINI cod. 05.9890.97.3 (optional)
MOUNTING RAILS KIT cod. 05.9890.97.3 (optional)
KIT SUPPORTS cod. 05.9890.97.3 (option)
JUEGO DE PIES cod. 05.9890.97.3 (opción)

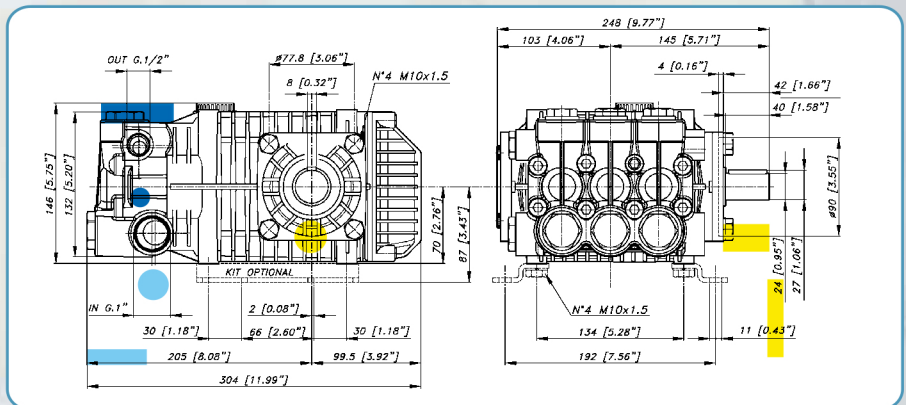

CARATTERISTICHE - FEATURES

PERFORMANCE CHART

MODELLO MODEL CODICE PART NR.	MAX		PRESS		RPM 950				RPM 1450				RPM 1725				PIST. CORSA PLUNG. STROKE	
	L/min	GPM	Bar	PSI	L/min	GPM	KW	HP	L/min	GPM	KW	HP	L/min	GPM	KW	HP	Dia. mm	mm
KKL 3021 06.4017.97.3	34.7	9.2	170	2465	19.5	5.2	6.5	8.7	29.5	7.8	9.8	13.2	34.7	9.2	11.6	15.5	22	19
			190	2755	19.4	5.1	7.2	9.7	29.3	7.7	10.9	14.7	34.5	9.1	12.9	17.3		
			210	3045	19.3	5.1	8.0	10.7	29.2	7.7	12.0	16.1	34.4	9.1	14.2	19.0		
KKL 3316 06.4018.97.3	38.7	10.2	120	1740	21.7	5.7	5.1	6.9	32.8	8.7	7.7	10.4	38.7	10.2	9.1	12.2	25	16.4
			140	2030	21.6	5.7	5.9	8.0	32.7	8.6	9.0	12.0	38.5	10.2	10.6	14.2		
			160	2320	21.5	5.7	6.8	9.1	32.5	8.6	10.2	13.7	38.3	10.1	12.0	16.1		
KKL 3816 06.4019.97.3	44.8	11.8	120	1740	25.2	6.7	5.9	8.0	38.1	10.1	9.0	12.0	44.8	11.8	10.6	14.2	25	19
			140	2030	25.1	6.6	6.9	9.2	37.9	10.0	10.4	14.0	44.6	11.8	12.3	16.4		
			160	2320	24.9	6.6	7.8	10.5	37.7	10.0	11.8	15.9	44.4	11.7	13.9	18.7		
KKL 4216 06.4035.97.A	49.5	13.1	120	1740	27.8	7.4	6.6	8.8	42.1	11.1	9.9	13.3	49.5	13.1	11.7	15.7	25	21
			140	2030	27.7	7.3	7.6	10.2	41.9	11.1	11.5	15.4	49.3	13.0	13.6	18.2		
			160	2320	27.6	7.3	8.7	11.6	41.6	11.0	13.1	17.5	49.1	13.0	15.4	20.7		
KKL 4816 06.4033.97.3	56.6	15.0	120	1740	31.8	8.4	7.5	10.1	48.1	12.7	11.3	15.2	56.6	15.0	13.3	17.9	25	24
			140	2030	31.6	8.4	8.7	11.7	47.8	12.6	13.1	17.6	56.3	14.9	15.5	20.8		
			160	2320	31.5	8.3	9.9	13.3	47.6	12.6	15.0	20.1	56.1	14.8	17.6	23.6		