

highest state PRECISION QUALITY OF THE ART highest customized WBH-F QUALITY PRECISION

CARATTERISTICHE - SPECIFICATIONS

IN	DIAMETER	\varnothing	3/8 BSP
	PRESS.	Min.	1 bar 15 PSI
		Max.	6 bar 87 PSI
TEMP.	Max.	60° C. 140° F.	
OUT	DIAMETER	\varnothing	3/8 BSP
SHAFT		\varnothing	HOLLOW 5/8"
OIL		SAE 75W 90	0.5 litri 0.13 U.S.G.
PESO WEIGHT		Kg / lbs	6.1 / 13.4



M - NEMA 56C -5/8"



OPTIONAL

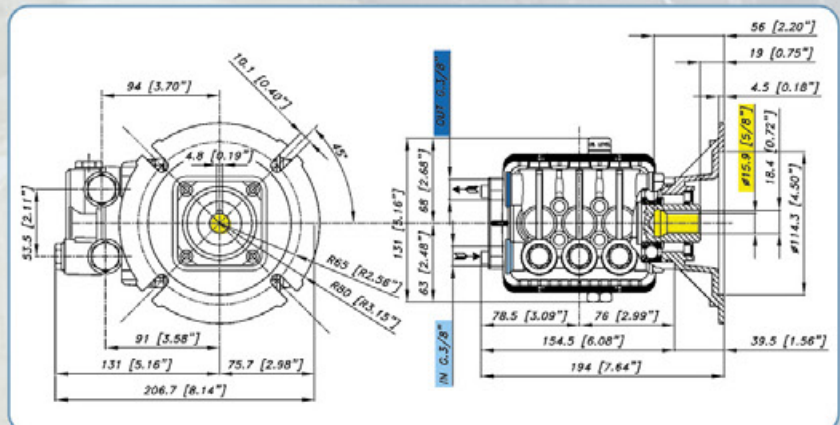

CARATTERISTICHE - FEATURES

WBH-F 3450 rpm

PERFORMANCE CHART

CODICE PART NR.	MODELLO MODEL	PRESS MAX / MAX PRESSURE		PORTATA / FLOW		POTENZA / POWER		PIST. PLUNG. Dia. mm	CORSA STROKE mm
		Bar	PSI	L/min	GPM	KW	HP		
02.6120.97.3	WBH 1521-F	105	1500	7.8	2.1	1.6	2.1	15	4.8
02.6121.97.3	WBH 2021-F	140	2000	7.8	2.1	2.1	2.8		
02.6122.97.3	WBH 2521-F	175	2500	7.8	2.1	2.6	3.5		
02.6123.97.3	WBH 1725-F	115	1700	9.5	2.5	2.2	3.0	15	6
02.6124.97.3	WBH 2525-F	175	2500	9.5	2.5	3.2	4.3		
02.6125.97.3	WBH 1430-F	95	1400	11.7	3.1	2.2	3.0	15	7.2
02.6126.97.3	WBH 1930-F	130	1900	11.7	3.1	3.0	4.0		
02.6127.97.3	WBH 2430-F	170	2400	11.7	3.1	3.7	5.0		
02.6128.97.3	WBH 1537-F	105	1500	14.0	3.7	2.8	3.8	15	8.6
02.6129.97.3	WBH 2037-F	140	2000	14.0	3.7	3.7	5.0		