

highest quality state of the art  
 customized precision  
**WIMG-W 1"**

**CARATTERISTICHE - SPECIFICATIONS**

IN	DIAMETER	$\varnothing$	1/2 BSP
	PRESS.	Min.	1 bar 15 PSI
		Max.	6 bar 87 PSI
TEMP.	Max.	60° C. 140° F.	
OUT	DIAMETER	$\varnothing$	3/8 BSP
SHAFT		$\varnothing$	HOLLOW 1"
OIL		SAE 75W 90	0.6 litri 0.16 U.S.G.
PESO WEIGHT		Kg / lbs	8.8 / 19.3

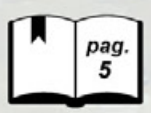

**M** SAE J609 -1"

→ > >> Dx R Bz B

Con valvola depressurizzatrice incorporata e eiettore detergente regolabile  
 With unloader valve and adjustable injector built-in  
 Avec régulateur de pression by-pass et éjecteur réglable incorporés  
 Con válvula de regulación de presión y eyector regulable incorporados

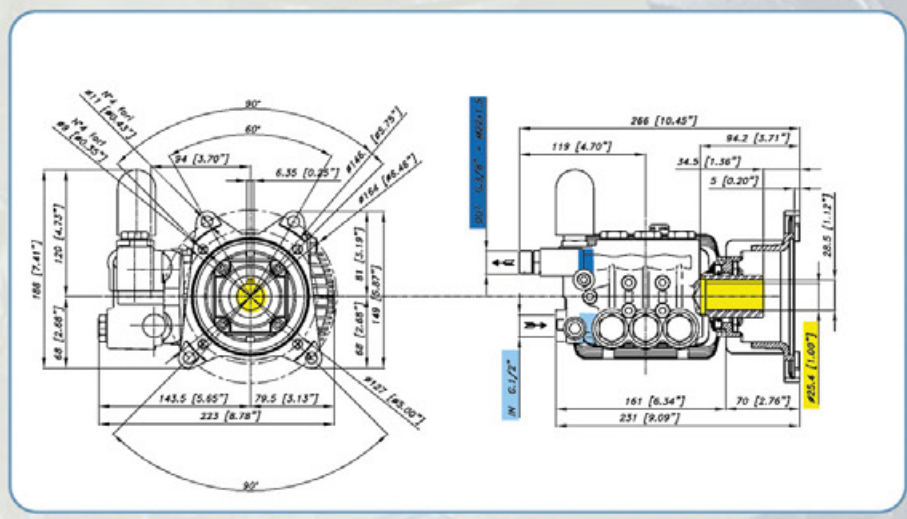

**WIMG-W 1" 3450 rpm**

**CARATTERISTICHE - FEATURES** **PERFORMANCE CHART**

CODICE PART NR.	MODELLO MODEL	PRESS MAX / MAX PRESSURE		PORTATA / FLOW		POTENZA / POWER			PIST. PLUNG. Dia. mm	CORSA STROKE mm
		Bar	PSI	L/min	GPM	KW	HP	HP engine		
04.8760.97.3	WIMG 4031-W	280	4000	11.8	3.1	6.4	8.6	11	15	7.2
04.8762.97.3	WIMG 4037-W	280	4000	14.1	3.7	7.7	10.3	12	15	8.6
04.8764.97.3	WIMG 4043-W	280	4000	16.1	4.3	8.7	11.7	14	15	9.8